

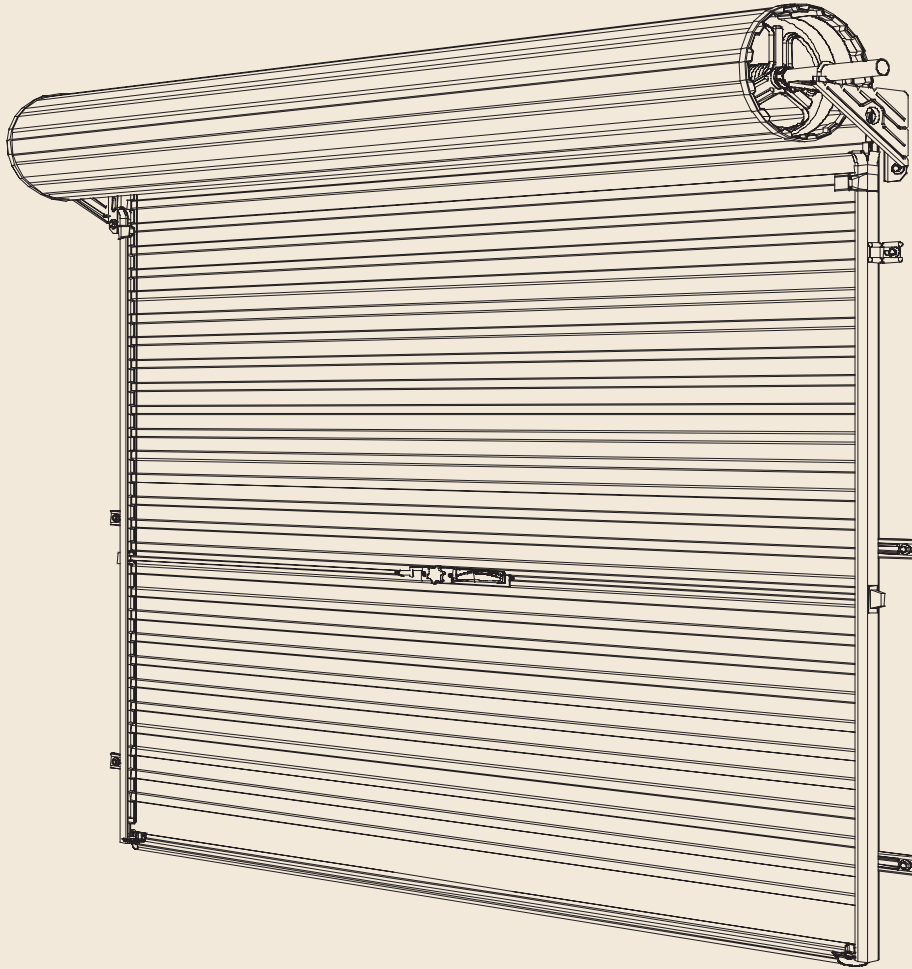

Roll-A-Door[®]

Series 1 Squareline Deluxe Doors

INSTALLATION INSTRUCTIONS



DISCLAIMER

*THESE INSTRUCTIONS ARE INTENDED FOR
PROFESSIONAL GARAGE DOOR INSTALLERS*

Note: All references are taken from inside looking out



CONTENTS

1.0	BEFORE YOU START	3
1.1	SAFETY CHECKLIST	3
1.2	FASTENER RECOMMENDATIONS FOR FITTING GARAGE DOORS	4
1.3	REQUIREMENTS BEFORE INSTALLATION	5
1.4	FIXING REQUIREMENTS	6
1.5	TOOLS CHECKLIST	6
1.6	PARTS CHECKLIST	6
2.0	INSTALLATION	7
2.1	INSTALL FIRST BRACKET	7
2.2	INSTALL SECOND BRACKET	7
2.3	PLACE DOOR ON BRACKETS	8
2.4	POSITION DOOR	8
2.5	TENSION THE SPRINGS	9
2.6	ATTACHING STOP	9
2.7	GUIDES	10
2.8	FITTING HANDLE	10
2.9	CENTRE LIFT LOCK	11
2.10	FINAL ADJUSTMENT	12
2.11	TO ADJUST SPRING TENSION (FOLLOW CAREFULLY)	12
2.12	FIXING ALTERNATIVES	13
3.0	AFTER INSTALLATION CARE	14

1.0 BEFORE YOU START

Your new B&D Roll-A-Door® has been designed to provide security, attractive appearance and smooth, low effort operation. Your door will not provide optimum performance unless it is installed correctly. Please follow the instructions carefully.

NOTE: No guarantee will be given or responsibility accepted by the manufacturers if the door is not installed as instructed. For satisfactory door operation please follow the instructions carefully.

1.1 SAFETY CHECKLIST

The following hazards and hazard controls have been identified for installers during the installation of this door.

Hazard	Control
<ul style="list-style-type: none"> Housekeeping - risk of slip trip or fall Housekeeping - risk of injury to other people or animals in the installers work area 	<ul style="list-style-type: none"> Tidy up site prior to start work as a minimum area should be at least the area of the installation back into the garage and 2 metres in front If the Site housekeeping is deemed to be unsafe do not install the door Keep all people well clear of installers work area with appropriate signage and discussion with owner
<ul style="list-style-type: none"> Manual handling when moving the door from the Trailer or Ute to the installation area - risk of musculoskeletal injury Manual handling when installing Doors & Openers particularly above head height - risk of musculoskeletal injury or twisting Manual handling when installing tracks and torsion bars - risk of musculoskeletal injury Manual Handling when installing the door opener - risk of musculoskeletal injury or twisting 	<ul style="list-style-type: none"> Correct lifting technique for Roller Door Use of 2 person lifts Use of mechanical aids such as lifting stands, forklift, cranes Avoid twisting (Practice correct lifting techniques) Correct use of ladders while installing tracks Use of correct technique of knotted rope installation aids
<ul style="list-style-type: none"> Working at heights and working with ladders, scissor lifts, scaffold - risk of fall from height 	<ul style="list-style-type: none"> Ladder check Ladder placement Do not work off the top rung
<ul style="list-style-type: none"> Sharp edges on Door, tracks or related jewellery - risk of laceration 	<ul style="list-style-type: none"> Wear appropriate PPE (Dyneema cut off Gloves) Follow instruction explicitly particularly for the installation of some parts of the doors as the unrolled cut out edges presents a very sharp edge
<ul style="list-style-type: none"> Pinch points - risk of cut, puncture or crush injury 	<ul style="list-style-type: none"> Wear appropriate PPE and keep hands well clear of pinch points Ensure hands well clear of the panels
<ul style="list-style-type: none"> Use of hand tools - risk of eye injury, laceration cut stab or puncture injuries (Tools checklist) Use of Electric/ Battery or pneumatic tools - noise hazard Use of cutting tools creating sparks - risk of fire 	<ul style="list-style-type: none"> Wear appropriate PPE and utilise operators manual Use appropriate noise/hearing protection in the form of ear plugs or ear muffs Ensure appropriate fire protection available and housekeeping to ensure that flammable liquids or materials are removed from the area of work
<ul style="list-style-type: none"> Tension spring - risk of release of stored energy (various door parts, tools, jewellery striking installer on the head or body) 	<ul style="list-style-type: none"> Ensure door is correctly secured Ensure that pipe wrench is fitted correctly to the axle and if it is gripped onto the axle do not underestimate the tension in the spring when undoing the clamps Ensure the correct length pipe wrench is utilised Ensure correct bolts are tightened or loosened to ensure there is no release or controlled release of energy from the spring through the pipe wrench Keep hands clear of the pipe wrench at all times Keep head clear of the pipe wrench at all times
<ul style="list-style-type: none"> Position the door on the brackets, there is a risk of the door falling from the brackets striking a person 	<ul style="list-style-type: none"> Ensure the door is immediately fastened to the bracket with the "U" Bolt Ensure no-one ever walks under a door sitting on a bracket

1.2 FASTENER RECOMMENDATIONS FOR FITTING GARAGE DOORS

MATERIAL	FASTENER TYPE(S)	DIAMETER OR TYPE		LENGTH OF FASTENER (See Note)
New Solid Brick	Coach Bolts (Hex Lag Screw) - combined with wall plugs	5/16"	X	1½"
		3/8"	X	2"
	Macplugs (wall plugs) to suit above	5/16"	X	50mm
		3/8"	X	60mm
	HLC Sleeve Anchors (Dyna Bolts)	12mm	X	55mm
New Hollow Brick	HRD-VGK or HGK-VGS (Hex Head) Frame Anchors	10mm	X	60mm
New Solid Concrete	Coach Bolts (Hex Lag Screw) - combined with wall plugs	5/16"	X	1½"
		3/8"	X	2"
	Macplugs (wall plugs) to suit above	5/16"	X	50mm
		3/8"	X	60mm
	HLC Sleeve Anchors (Dyna Bolts)	12mm	X	55mm
Aerated Concrete e.g. (HEBEL)	Fischer Nylon Twist Lock Anchor Type GB 14	14mm	X	85mm
Steel Framing e.g. BHP Framing (with rear access)	Hex Head Bolt Zinc Plated, Hexagon Nuts Zinc Plated, Washers Zinc Plated	5/16"	X	1"
		3/8"	X	1"
		10mm	X	25mm
		12mm	X	25mm
Heavy Gauge Steel	Hex Head Tek	14-20	X	22mm
Light Steel Framing e.g. BHP House Framing (no rear access)	Heavy Duty Kap Toggle	10mm	X	100mm
		12mm	X	100mm
	Hex Head Tek	6-10	X	20mm
New Timber	Coach Bolts (Hex Lag Screw)	5/16"	X	1½"
		3/8"	X	2"
	Hex Head Tek	14-10	X	50mm

IMPORTANT NOTES:

- For installation to materials not covered in the above chart, the installer should seek expert advice from a qualified builder.
- Minimum length of fastener does not exclude use of longer lengths. Decision must be made by fitter to ensure adequate strength.
- Recommendations for old materials or materials not in good condition are not included. If in doubt about the strength of the material seek specialist advice.
- Fasteners for sectional door spring brackets and top track brackets in masonry should be at least 5/16" x 2.5" long or metric equivalent.
- HEBEL Fischer type fastener should be installed 150mm from edge of blocks. Minimum overlap of door should be approximately 115mm (S1), 110mm (S3) and 90mm (Panelift). Add 50mm more if mounted on panels instead of blocks.

IMPORTANT INFORMATION ON FASTENERS

Coach bolts/screws supplied with this product are suitable for fastening to timber jambs.

Correct and safe fastening to other materials may require different fasteners.

The installer must select and use fasteners appropriate to the material into which they are being fixed.

1.3 REQUIREMENTS BEFORE INSTALLATION

OPENING REQUIREMENTS

The door is designed to be mounted behind the opening, therefore you will need to measure and check:

OPENING WIDTH - As the door overlaps each side by 25mm or more, the door should be 50mm wider than the opening. A wider door can be fitted as long as additional sideroom and fixing is available. If the door is too narrow, the opening should be reduced by fitting jambs to the inside of the opening (Alternative Fixings No. 1).

OPENING HEIGHT - The door will fit any opening height up to the marked door size (the guides can be cut to suit). After installation the walk-in clearance, under the door when installed, will be reduced by approximately 80mm to allow access to the handle.

LEVEL AND PLUMB - The door must be installed in an absolutely level position, if opening is not level and square, appearance and/or sideroom requirements will be affected. Where jambs are out of plumb, extra sideroom or opening modifications may be required to allow the door guides to stand back from the opening edge. The floor should be level or recessed across the opening to avoid gaps.

STRUCTURAL SUITABILITY - Ensure the opening is strong enough to support the door. If unsure, consult builder or professional door installer.

SIDEROOM - A minimum of 75mm (100mm desirable) of sideroom is required behind the opening and should extend above the head to allow for bracket fixing. Sideroom on one side of 115mm is required if a B&D Controll-A-Door® garage door opener is to be fitted now or in the future.

OBSTRUCTIONS - Ensure that the surface where the door will be fitted is flush and smooth, and the area behind the opening is free from any protrusions.

HEADROOM - See diagram below. If the door is installed lower into the opening than shown, additional loss of walk-in clearance will result. The fitting of a head infill panel may also be necessary, in order to improve the external appearance (See Alternative Fixings No. 2).

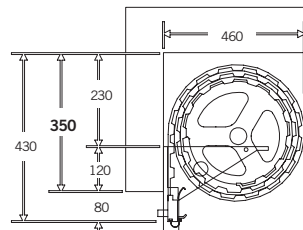
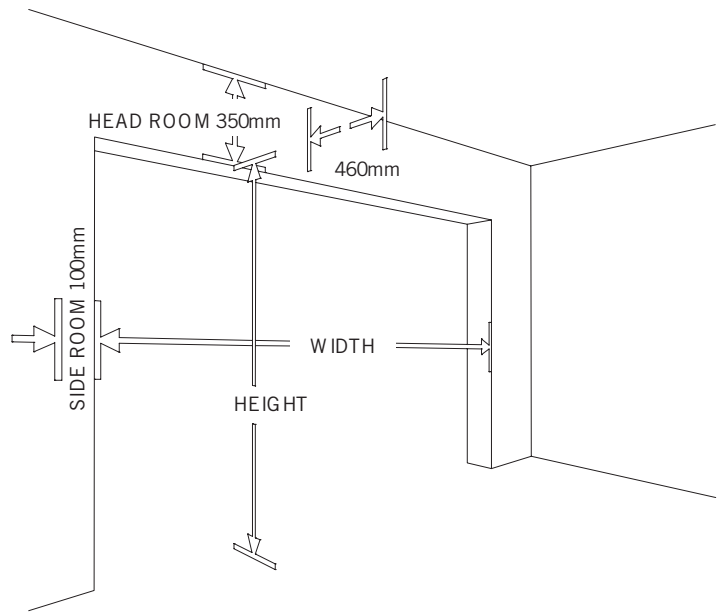

NORMAL HEADROOM
Up to 2200mm High

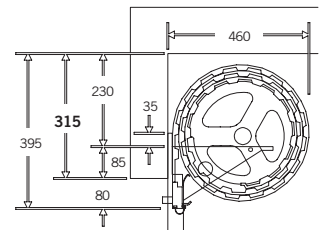

RESTRICTED HEADROOM
Up to 2200mm High

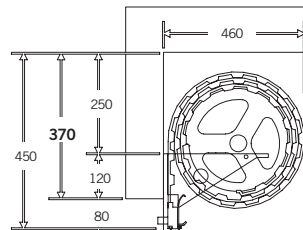

NORMAL HEADROOM
Over 2200mm High

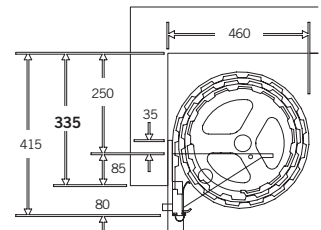

RESTRICTED HEADROOM
Over 2200mm High

1.4 FIXING REQUIREMENTS

Coach screws are supplied with the door for fitting to timber. Correct and safe fastening to other materials may require different fasteners. The installer must select and use fasteners appropriate to the material into which they are being fixed.

NOTE: It is the installer's responsibility to ensure that the fixing methods are sound.

1.5 TOOLS CHECKLIST

Tools required to install the door. You will also need assistance to help you lift the door up safely and carry out some other steps.

- a power drill & bits
- phillips head screwdriver
- a file
- a socket set
- a hacksaw
- spirit level
- 2 stepladders
- Stanley knife
- adhesive tape
- marking pen
- 450mm (18") pipe wrench
- 400mm softwood chock
- water level (10mm diameter clear tube by 6m long)

1.6 PARTS CHECKLIST

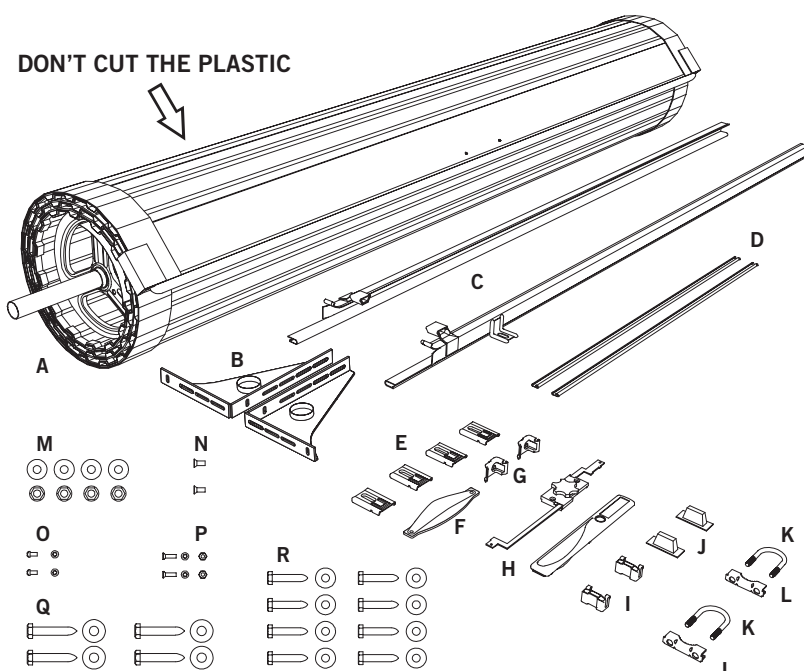

- A. 1 - rolled, plastic wrapped door
- B. 2 - "A" style brackets, left and right handed
- C. 2 - door guides, left and right handed
- D. 2 - steel locking bars

1 small parts bag containing:

- E. 4 to 10 - guide clips
- F. 1 - door handle and fixings to suit
- G. 2 - metal stops
- H. 1 - faceplate and lock assembly 2 - keys
- I. 2 - locking bar retainer
- J. 2 - locking bar covers
- K. 2 - "U" bolts
- L. 2 - axle/bracket saddles
- M. 4 - 8mm nuts and washer for "U" bolts
- N. 2 - counter sunk screws for handle
- O. 2 - 7mm x 4mm mushroom head screws
- P. 2 - 4mm x 6mm locking bar screws
- Q. 4 - 50mm x 10mm coach screws and washers
- R. 8 to 12 - 40mm x 8mm coach screws and washers

2.0 INSTALLATION

2.1 INSTALL FIRST BRACKET

- Measure the door curtain width and mark where edge of the curtain will be, allowing for over lap on each side of the opening.
 - Add clearance of 10 to 75mm from edge of curtain to inside edge of bracket to determine positioning of the bracket. Also check this clearance if an opener is being fitted.
 - Normal Headroom** (350mm for doors up to 2200mm high, 370mm for doors over 2200mm high). Measure up 120mm from underside of the head. If the head is not level, measure up from the lowest side first.
Restricted Headroom (315mm for doors up to 2200mm high, 335mm for doors over 2200mm high). Measure down 230mm (or 250mm if door is over 2200mm high) from roof or lowest obstruction to the top of the bracket. (Bracket should be between 85mm and 100mm up from the lintel).
- If less headroom than shown above or no headroom is available**, follow the restricted headroom instructions and for appearance purposes fit a false head if necessary.
- Mark two hole positions using top and bottom slots of the bracket.
 - Drill both holes, then attach bracket using the 50mm x 10mm coach screws and washers supplied (or masonry anchors if fixing to brickwork).

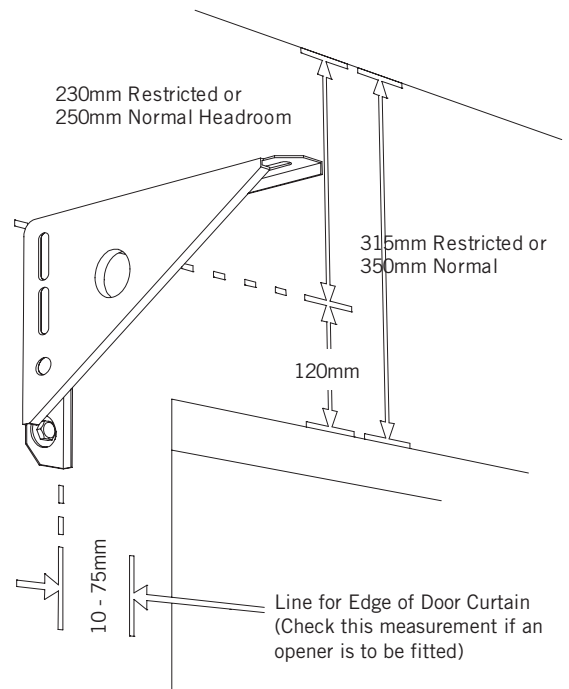

2.2 INSTALL SECOND BRACKET

- Using a water level mark the position for the second bracket. **NOTE:** The brackets must be perfectly level for the door to operate.
- Re-check levels then drill and fix as with first bracket.

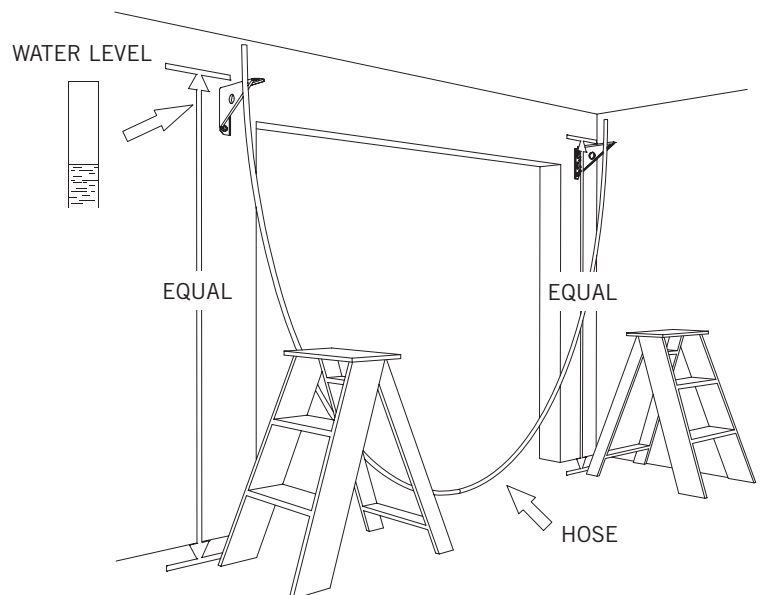

2.3 PLACE DOOR ON BRACKETS

- Check the axle length and cut if sideroom is limited. Before cutting, make sure the floating axle is free and centred. Centre will be found by rotating the axle a quarter turn in either direction then releasing. With centre found, make a clear mark on the axle against the hub for later reference.
- Lift door onto the brackets (the right way round so that the door will roll down from the front of the opening). Immediately loosely fit the "U" bolts, saddles, washers and nuts to the brackets in position shown. Fitting the 'U' bolts eliminates the door falling from the brackets. (Do not tighten until Step 2.4, c.)

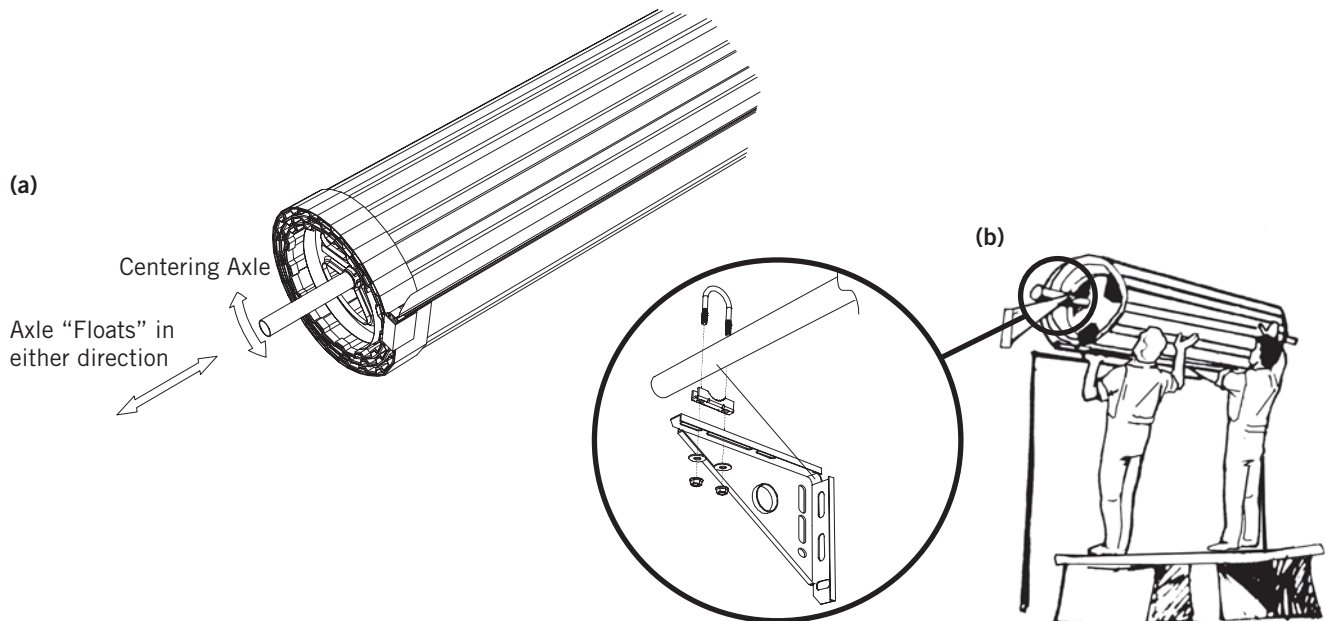

2.4 POSITION DOOR

- Centre the door with the opening, while ensuring the floating axle is also centred with the door.
Do this by lining up previous marks with the hub, then lift both the axle and the door together until it is centred with the opening.
- Rotate the curtain and axle so that the bottom rail of the door is positioned as shown (three o'clock).
- Push the axle forward in the slots (toward the opening) and tighten the nuts firmly without over-tightening. (10 Newton metres or 6.6 feet/pounds torque reading).

NOTE: Do not cut the plastic wrap or packaging yet.

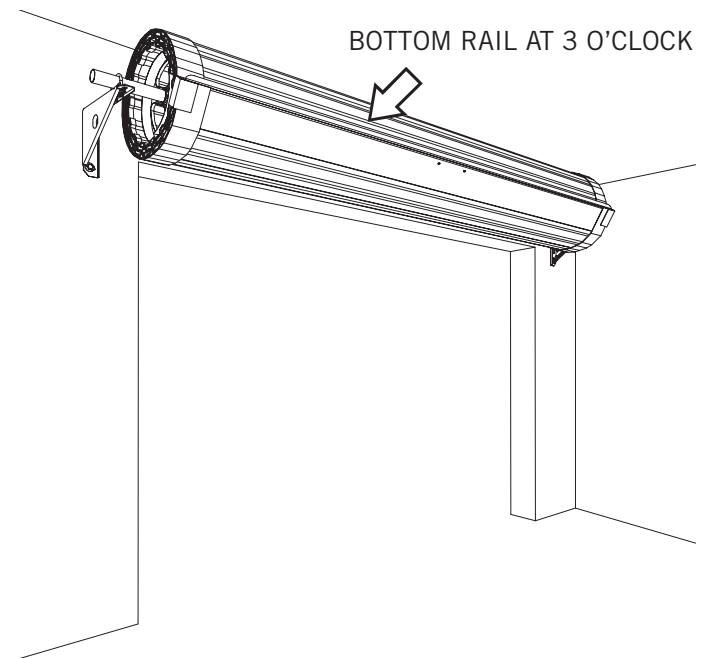

2.5 TENSION THE SPRINGS

FIRST PREPARE A SOFT WOOD CHOCK, ABOUT 400mm LONG.



THEN - Ensure that bottom rail is at the 3 o'clock position as shown in Step 4 - if not, refer to Step 2.4.

- a) Ensure both "U" bolts are tightened, then -
1. Rotate the door 1 1/2 turns in a forward direction to apply tension. Do not let go as the springs are now tensioned. See arrow in Fig (a).
 2. Hold the door firmly, **NOW** cut the plastic wrap along the bottom rail (taking care not to damage door surface or weatherseal).
- b) Pull the curtain down slowly and carefully position the wooden chock (or other appropriate stop) as shown in Fig (b). Take care not to damage door surface.

The chock will help hold the door until the guides and stops are fitted.

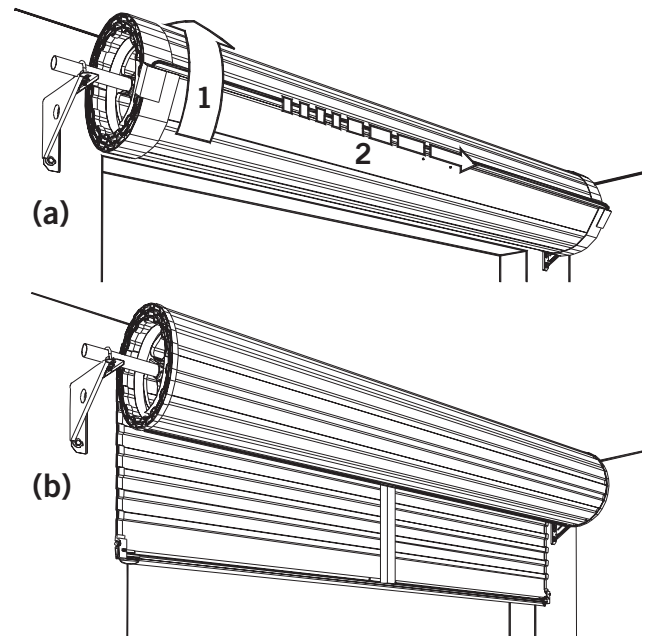

2.6 ATTACHING RAIL STOP

To attach metal stops to bottom rail of door.

- a) Hook stop behind lip in rail, as shown.
- b) Secure from underneath the rail with screws supplied. You will need to trim the weatherseal flush with the end of the bottom rail.

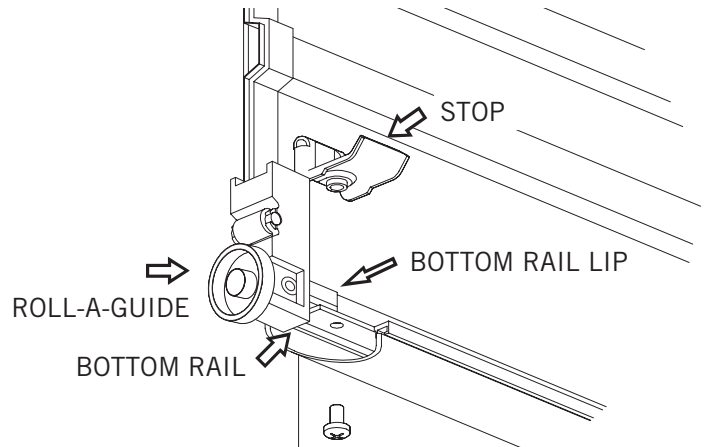

2.7 GUIDES

- Check that curtain overlaps equally on both sides.
- Check that guides are the correct length, that is, level with the brackets (or in the restricted headroom position are 35mm maximum above bracket). **NOTE:** Restricted headroom is not recommended when fitting an opener.
- Slide half the number of guide clips into each guide.
- Position the bottom clip 200mm from the floor with the rest evenly spaced along the guide. (Hint: to prevent clips from sliding down the guide, temporarily secure them with adhesive tape.) Now position one guide over the edge of the door curtain.
- Mark and drill the top fixed guide clip and secure using a 40mm x 8mm coach screw and washer, allowing 3mm clearance between the inside of the guide and plastic Roll-A-Guide.
- Ensuring guide is plumb, drill and fix remaining clips. (Note: if securing to uneven brickwork, packers may be required behind clips, to prevent them twisting out of square; also ensure that clips are positioned on secure bricks).
- With the top of the 2nd guide level with the first, repeat (e) and (f).
- Remove the chock and slowly lower the door removing plastic wrap as you pull door down, reposition the guides as necessary to allow smooth and even operation with 3mm clearance throughout.
- Ensure door curtain enters guides smoothly. It will be necessary to adjust the guide lead in to achieve this.

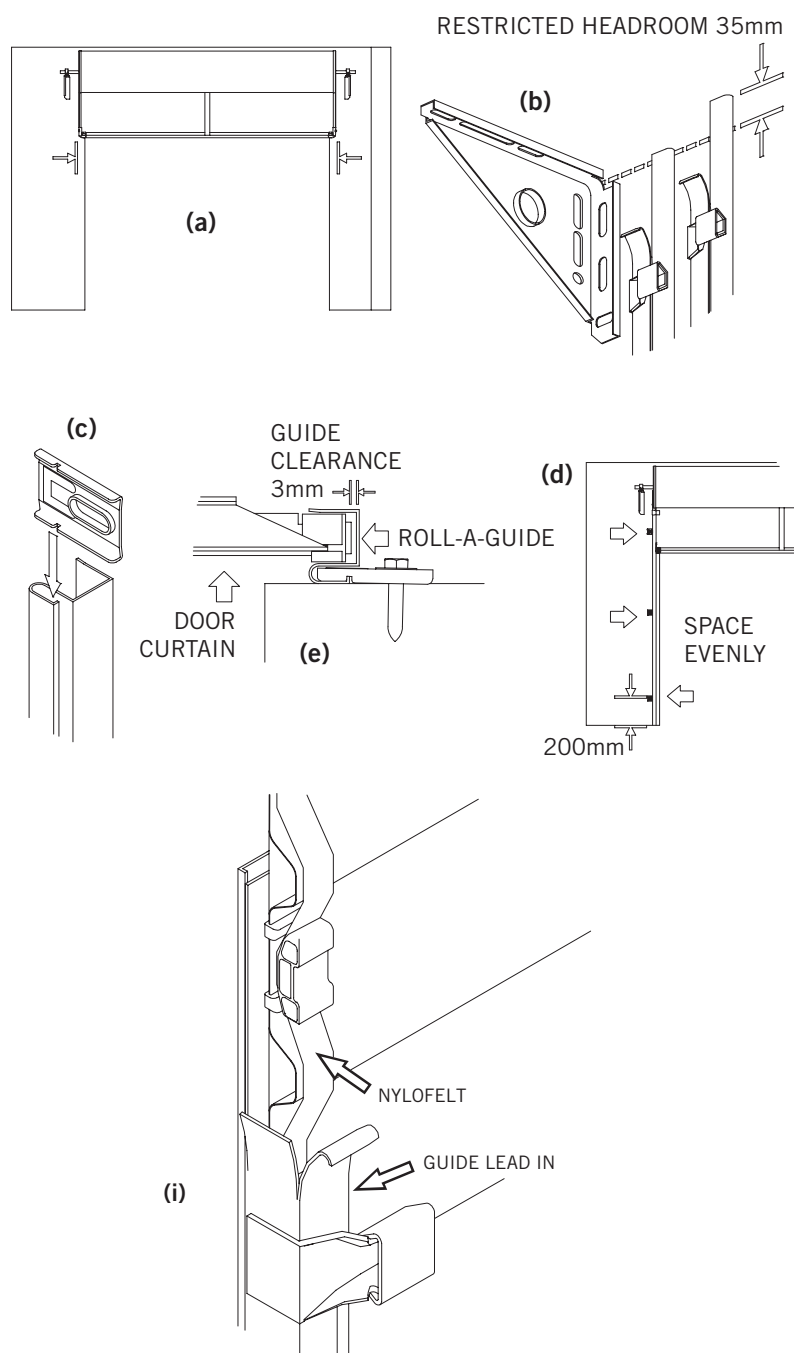

2.8 FITTING HANDLE

Fit the handle to the outside of the door using the screws, nuts and washers provided.

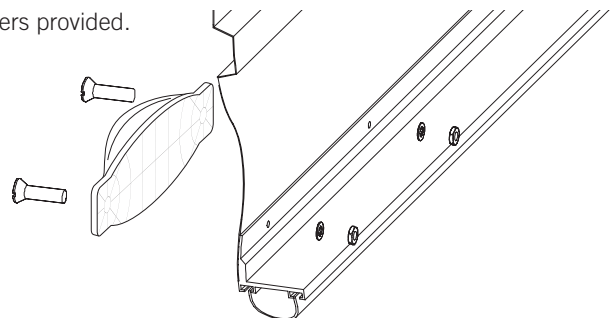

2.9 CENTRE LIFT LOCK

- a) Raise the curtain until the lock corrugation is visible above the door guides.
- b) Install locking bar retainer in line with lock corrugation by pushing retainer towards door edge, sliding the legs under the Nylofelt® and hooking them over the curtain edge (it is easier to hook legs one at a time). Ensure lock bar retainers sit squarely on door curtain. See Fig (b).
- c) Fit faceplate to outside of door where the hook will latch onto curtain edge, then slide faceplate as far to the right as possible. Use adhesive tape on outside to hold in position.
- d) Attach the lock body to the faceplate from the inside, using the mounting screws and washers. Do not over tighten the screws. See Fig (d).
- e) With the door in the closed position slide the end of the locking bars through the locking bar retainers, and while holding the bars level mark the side of the guides.
- f) Drill and file out a rectangular slot no longer than 25mm and no wider than 10mm. Ensure top of slot remains in line with top of locking bar.
- g) Slide bars through the guide slot, then back onto lock arms. Screw on securely using the 4mm x 6mm screws supplied. Ensure that locking bars do not protrude more than 20mm beyond guide when engaged in locked position. It may be necessary to adjust the length of the bars.
- h) Ensure a clean and dry guide surface. Wipe guide with clean rag.
- i) Peel off lining from lock bar cover and position over hole. Check that the movement of the locking bar is free.

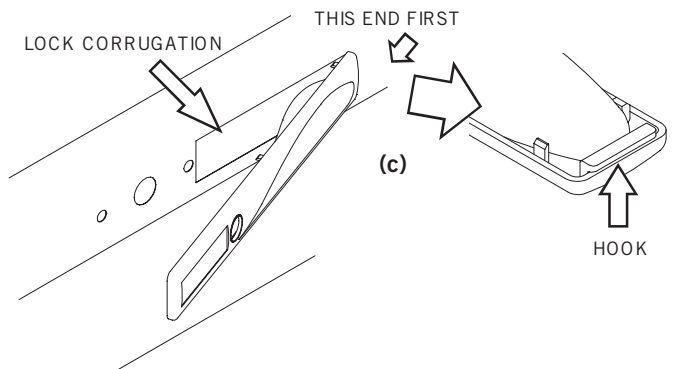
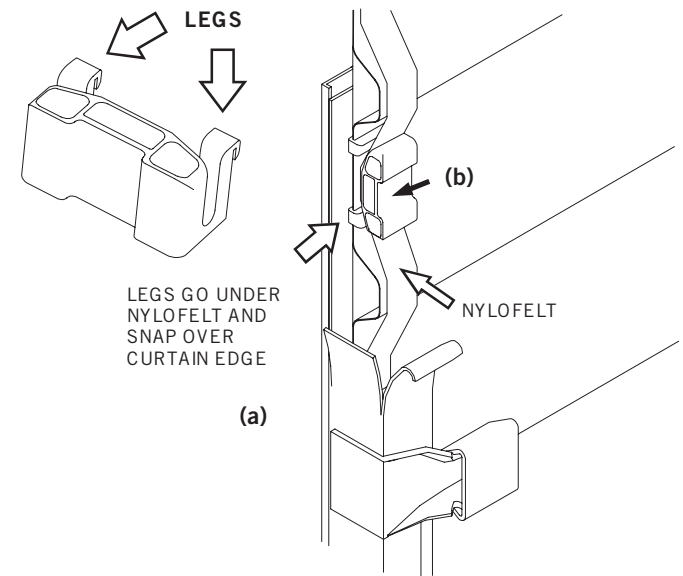

Note: the fitting of the lock bar covers is important to prevent possible finger entrapment - particularly important when the door is fitted with an automatic garage door opener.

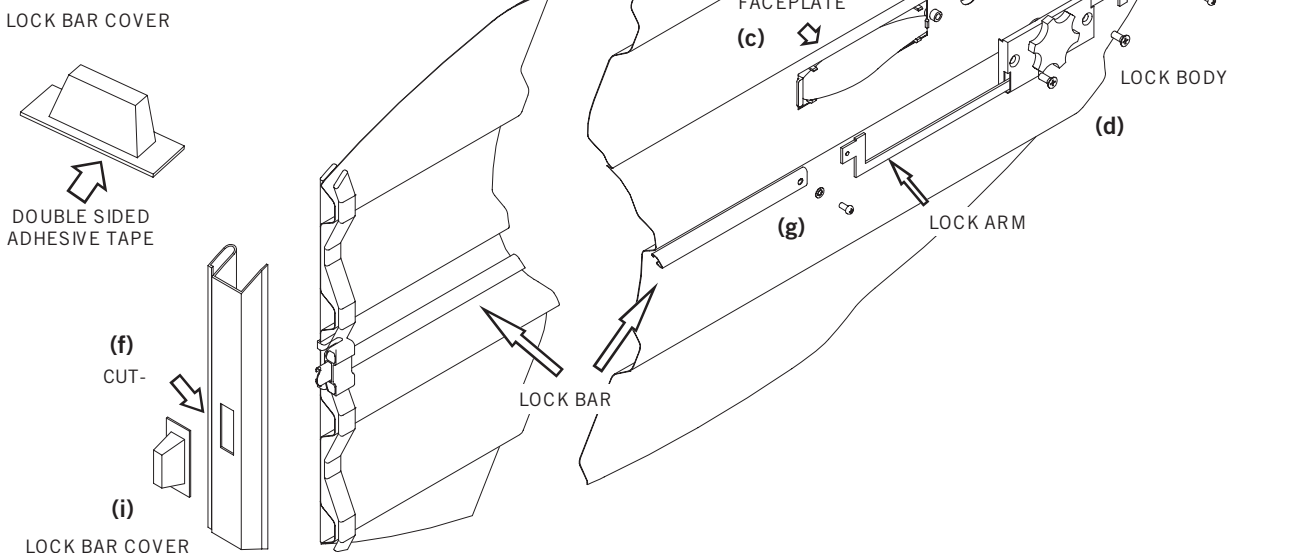

2.10 FINAL ADJUSTMENT

1. If the door is hard to operate in **ANY DIRECTION** check that the door is not jamming in the guides.

Check:

- a) the guide clearances;
- b) that guides are plumb;
- c) that the guide surfaces are clean and free from oil;
- d) that locking bars are the correct length; and
- e) that weatherseal is correct length.

2. If the door is hard to operate in **ONE DIRECTION**, the spring tension requires adjustment. See Step 2.11.

- a) If the door is hard to lift, but tends to drop, then increase the spring tension.
- b) If the door is hard to close, but tends to rise, then decrease the spring tension.

3. If the door rolls up crooked as shown right then:

Check:

- a) Brackets are level, refer to Step 2.
- b) Axle is centralised.
- c) Guides are plumb, refer to Step 7.

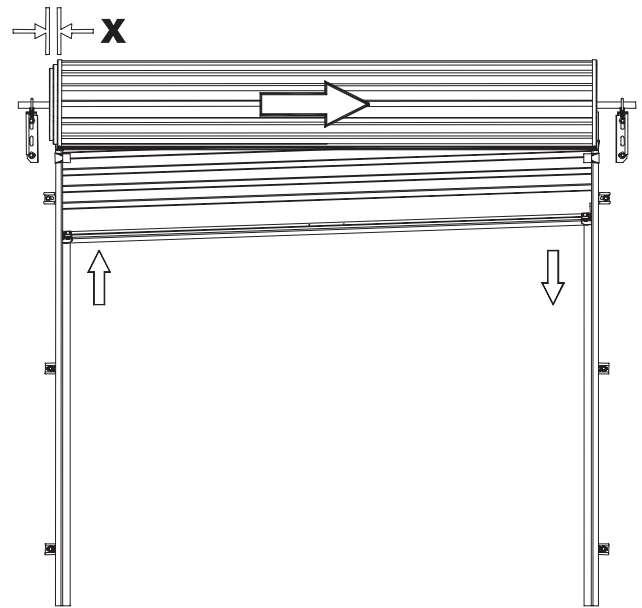

To centralise the axle - NOTE: these instructions are for the example illustrated - the axle needs moving to the right (to move left they would be vice versa). **NOTE:** Springs are tensioned and can cause injury.

With the door rolled up tie two ropes around the door roll approximately 300mm from each end, as a safety precaution. With the door rolled up, loosen one "U" bolt, then go to the other end of the door and with a firm hold on the axle, with a pipe wrench, loosen the second "U" bolt and move the axle to the right (the direction of the arrow in diagram). Move the door distance "X" in diagram.

Re-tighten one of the "U" bolts before releasing pipe wrench then **re-tighten** the other "U" bolt.

If the door is stiff to work or rattles over lead-in on top of guide, then refer to Step 7.

2.11 TO ADJUST SPRING TENSION (FOLLOW CAREFULLY)

1. With the door rolled up tie two ropes around the door roll approximately 300mm from each end, as a safety precaution.
2. With a person at each end of the door, hold the axle firmly with a large pipe wrench (Stillson) at least 450mm long.
3. Loosen the "U" bolt nuts at both ends and **KEEP A FIRM GRIP ON WRENCH.**
4. Rotate the axle in the required direction (see diagram).
5. Re-tighten the "U" bolts **BEFORE** releasing pipe wrench.
6. Test and repeat if further adjustment is necessary.

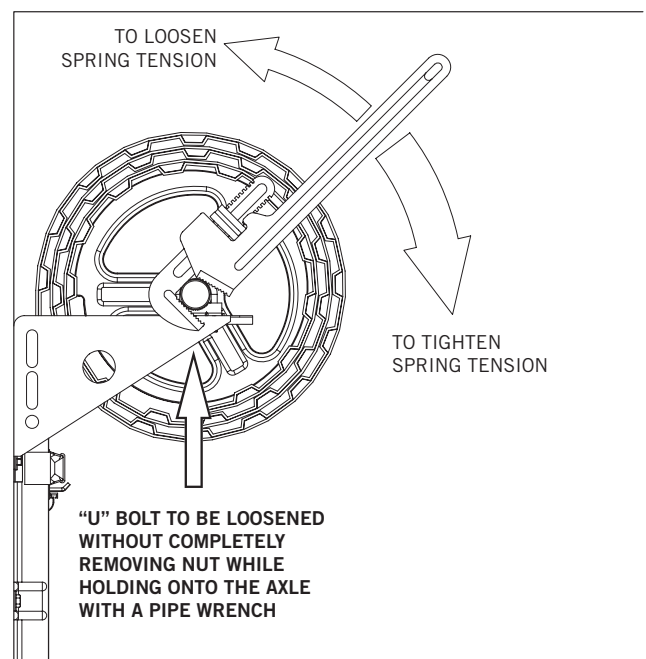

2.12 FIXING ALTERNATIVES

1. ALTERNATIVE GUIDE FITTING

- a) Exact opening size: Door over laps 25mm each side.
- b) Door is too wide: The guides can be set back inside from the opening edge.
- c) Door is too narrow: Reduce opening with quad or suitable timber ensuring that back of opening surface remains flush.

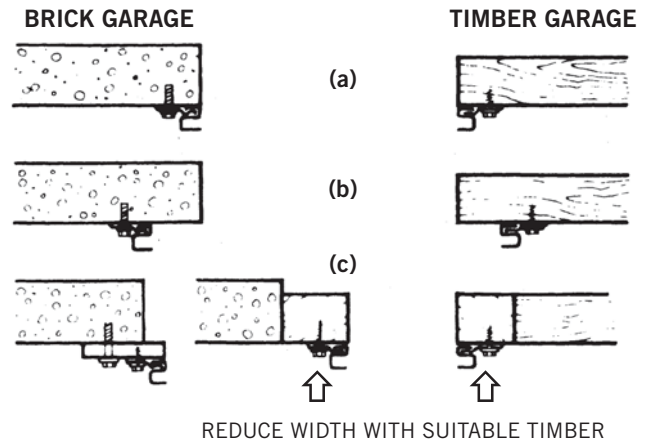

2. ALTERNATIVE HEADROOM FITTING: APPEARANCE IMPROVEMENT

If headroom is less than 250mm, a head infill panel should be fitted to improve the external appearance of garage opening. Note that the head infill panel must not be installed too close to the curtain face.

B&D Head Infill Panels are available to match or contrast with your door(s).

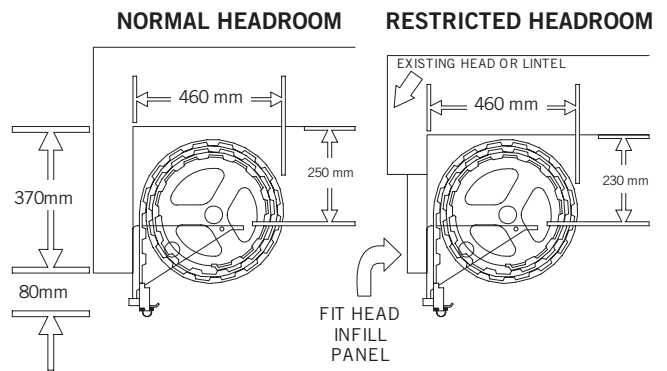

3. ALTERNATIVE BRACKET FITTING

An "A2" extended leg bracket should be used in conjunction with the standard "A" style bracket-under the following circumstances:

- a) If brickwork is old, or in any way suspect.
- b) If floater bricks are present, but sound fixing lower down the brickwork is available.
- c) When fixing to honeycomb or semi-hollow bricks.
- d) Where RSJ interferes with "A" bracket.

NOTE: Where old brick work with lime mortar is encountered, or any doubt exists as to the holding power of the masonry work, a timber frame, which continues above the head for bracket fixing, should be fitted on the back surface of the opening.

When fixing brackets to timber, the heavier coach screws supplied are usually adequate. In some cases, especially where timber is very soft, old or insecure, coach bolts should be used.

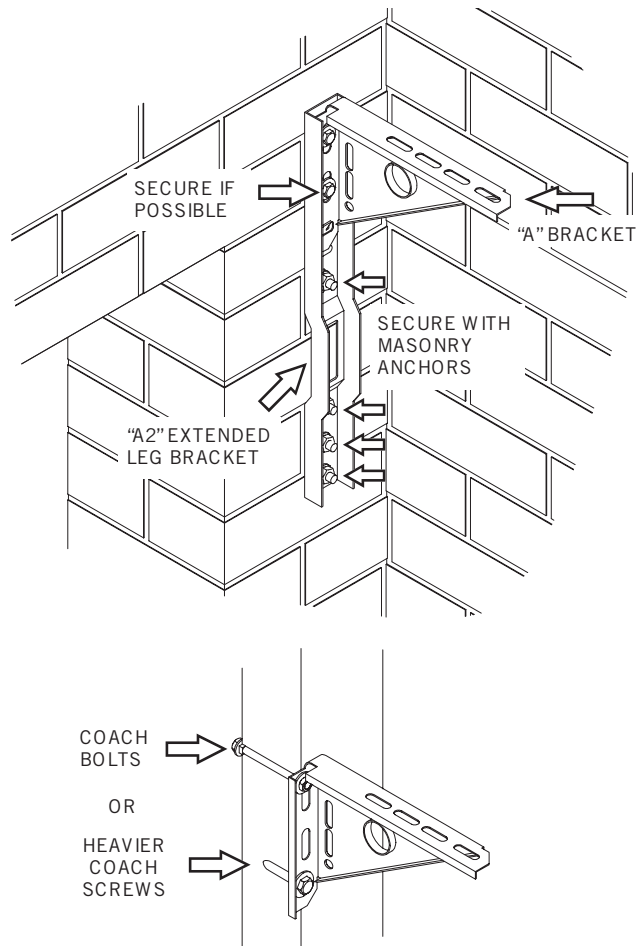

3.0 AFTER INSTALLATION CARE

GENERAL CARE OF YOUR ROLL-A-DOOR®

CLEANING

BLUESCOPE COLORBOND® FINISH Your B&D Roll-A-Door® door has been pre-painted with a silicone modified polyester formulation, which is one of the best paint films commercially available today. However, all exposed surfaces require some attention to guard against the premature onset of corrosion and any other harmful atmospheric effects. In our atmosphere there are harmful deposits that gather on the door surface and if not removed regularly, will seriously affect the appearance and life of the door.

Washing of the door with clean water and a cloth every 14 days is recommended – particular care should be taken to clean areas of the door not normally washed by rain, including the top of the door roll inside the garage.

NOTE: In locations where there is likely to be salt in the air or industrial fallout is severe, more frequent washing is advisable and additional protection of the surface maybe required.

Touch-up paint, if required, is available from your B&D dealer.

LOCK

Your lock does not require special maintenance, however, if the keyway becomes stiff, the application of powdered graphite is recommended – do not grease or oil the lock. The faceplate should be washed with soapy water and rinsed well. Strong solvents, such as acetone, should not be used – these will damage the surface. **WARNING!** Do not disassemble the lock mechanism.

When opening the door, always make sure the key is with drawn from the lock – if this is not done, the lock mechanism could be damaged and the key bent or broken.

We suggest you record your full Key letter and Number on the front of this manual and if replacement keys are required they can be obtained from your nearest B&D office, simply by quoting this number. If the keys have been lost and the number not recorded, it can be found stamped into the locking arm at the back of the mechanism.

NYLOFELT® On no account should you use grease or oil in the door guides or on the Nylofelt® running strips – the grease or oil will clog the Nylofelt® and spoil the operation of the door. An occasional wipe with a cloth dampened with mineral turps or methylated spirits, down the inside of each guide, is very beneficial in removing any trace of grease or dirt.

After the guides have been cleaned, a silicon spray may be used in the guides.

NOTE: WD40 or similar oil based sprays are not silicon and should not be used.

Care should be taken not to damage the Nylofelt®, however, if Nylofelt® is cut or damaged, a lighted match should be used to quickly seal the ends of the nylon braiding, so as to stop any further deterioration.

REGULAR MAINTENANCE REQUIRED

B&D recommends that you check the operation of your Roll-A-Door® at least every six months (more regularly in extreme environments or frequent use). The effort required to manually open and to manually close the door should be about the same (if door has an automatic opener, put into manual mode before testing door). If the door is difficult to operate in either direction (up or down) then check:

- 1) that the Nylofelt® running strips on each side of the door have not slipped from the edge and are jamming the door;
- 2) that the door is running correctly in the guides and the guides are straight and perpendicular; and
- 3) that the inside surfaces of the guides are clean and free of obstructions. (see paragraph on care of Nylofelt®)

If you have checked these (and corrected where necessary) and the door is still difficult to operate, , then your door will need a service to adjust the spring tension and possibly other operational parts of the door. This service should only be carried out by an experienced door technician, using the correct tools.

If you have an automatic opener fitted to your door, it is particularly important that you ensure the optimum operation of the door, otherwise you may reduce the effective life of the opener.

To keep your door running well, it is recommended that your door be serviced, by an experienced door technician, every 12 months (more regularly in extreme environments or frequent use), or earlier if required.

SPRING TENSION

It is natural for springs to lose tension over time. When spring tension is adjusted or when your door is first installed it is usual to apply a little more tension than is required for balanced operation, to allow for the normal “settling in” of the springs.

WARRANTY

The B&D Roll-A-Door® in normal residential use is covered by a 7 year warranty on door curtain, 12 months on surface (excludes salt corrosion), all other parts 12 months, including lock. For industrial/commercial applications the door is covered by 12 month warranty.

Warranty conditional on proper care as recommended above. Full details of the warranty are available from your nearest B&D office or visit the B&D website: www.bnd.com.au

B&D Doors Office Locations:

New South Wales:	34 Marigold St, Revesby 2212.	Phone: (02) 9722 5555
Queensland:	17 Oasis Court, Clontarf 4019.	Phone: (07) 3883 0200
Newcastle:	Unit 1/108 Mitchell Rd, Cardiff NSW 2285.	Phone: (02) 4956 8533
Victoria:	147-153 Canterbury Rd, Kilsyth 3137.	Phone: (03) 9237 7766

South Australia:	23 Frederick Rd, Royal Park 5014.	Phone: (08) 8440 4747
Western Australia:	96 Mulgool Rd, Malaga 6090.	Phone: (08) 9247 8777
International/Export:	34 Marigold St, Revesby 2212.	Phone: +61 (0)2 9722 5555



Prefixed trademarks are the property of B&D Australia Pty Ltd
B&D Doors & Openers is a division of B&D Australia Pty Ltd, an Alesco company
ABN 25 010 473 971
Copyright 2011 B&D Australia Pty Ltd.